

A Universal Circuit for Studying and Generating Chaos—Part II: Strange Attractors

Leon O. Chua, Chai Wah Wu, Anshan Huang, and Guo-Qun Zhong

Abstract— In a companion paper [1], we have shown how Chua’s oscillator is topologically conjugate to a class of 3-D systems. In this paper, we will use this result to approximate other chaotic systems in the literature which are not necessarily piecewise linear. To further illustrate the complexity of Chua’s oscillator, we also include a gallery of the many attractors found in Chua’s oscillator.

I. INTRODUCTION

CHUA’S OSCILLATOR [2] is a nonlinear electronic circuit that exhibits a wide variety of chaos and bifurcation phenomena. Its state equations are given by

$$\left. \begin{aligned} \frac{dv_2}{dt} &= \frac{1}{C_1} [G(v_2 - v_1) - f(v_1)] \\ \frac{dv_1}{dt} &= \frac{1}{C_2} [G(v_1 - v_2 + i_3)] \\ \frac{di_3}{dt} &= -\frac{1}{L} (v_2 + R_0 i_3) \end{aligned} \right\} \quad (1)$$

where

$$G = \frac{1}{R}$$

and

$$f(v_1) = G_b v_1 + \frac{1}{2} (G_a - G_b) \{|v_1 + E| - |v_1 - E|\}. \quad (2)$$

By a change of variables, the state equations of Chua’s oscillator (1) can be transformed into the following dimensionless form:

$$\left. \begin{aligned} \frac{dx}{d\tau} &= k\alpha(y - x - f(x)) \\ \frac{dy}{d\tau} &= k(x - y + z) \\ \frac{dz}{d\tau} &= k(-\beta y - \gamma z) \\ f(x) &= bx + \frac{1}{2}(a - b)\{|x + 1| - |x - 1|\} \end{aligned} \right\} \quad (3)$$

where

$$\left. \begin{aligned} x &\triangleq \frac{v_1}{E}, \quad y \triangleq \frac{v_2}{E}, \quad z \triangleq i_3 \left(\frac{R}{E}\right) \\ \alpha &\triangleq \frac{C_2}{C_1}, \quad \beta \triangleq \frac{R^2 C_2}{L}, \quad \gamma \triangleq \frac{R R_0 C_2}{L} \\ a &\triangleq R G_a, \quad b \triangleq R G_b, \quad \tau \triangleq \frac{t}{[R C_2]} \end{aligned} \right\} \quad (4)$$

and

$$k = 1, \quad \text{if } R C_2 > 0$$

$$k = -1, \quad \text{if } R C_2 < 0$$

Manuscript received May 15, 1993; revised August 10, 1993. This paper was recommended by Guest Editor L. O. Chua. This work was supported by the Office of Naval Research under grant N00014-89-J-1402 and by the National Science Foundation under grant MIP 86-14000.

The authors are with the Electronics Research Laboratory and Department of Electrical Engineering and Computer Sciences, University of California, Berkeley, CA 94720.

IEEE Log Number 9211612.

In [3], it was proved that (1) is topologically conjugate to a large class of 3-D systems $\tilde{C} = \mathcal{C} \setminus \mathcal{E}_0$, where \mathcal{C} is the class of odd-symmetric continuous three-region piecewise-linear 3-D vector fields, and \mathcal{E}_0 is a measure zero set. The reader is referred to [1] for the definition of \mathcal{E}_0 . The algorithm for finding the parameters that make a Chua’s oscillator topologically conjugate to a particular vector field in \tilde{C} is as follows:

Algorithm 1:

- 1) Calculate the eigenvalues (μ'_1, μ'_2, μ'_3) and (ν'_1, ν'_2, ν'_3) associated with the linear and affine vector fields, respectively, of the circuit or system candidate whose attractor is being reproduced by Chua’s oscillator, up to a linear conjugacy.
- 2) Find a set of circuit parameters $\{C_1, C_2, L, R, R_0, G_a, G_b, E\}$ (or dimensionless parameters $\{\alpha, \beta, \gamma, a, b, k\}$) so that the resulting eigenvalues μ_j, ν_j for Chua’s oscillator satisfy $\mu_j = \mu'_j$ and $\nu_j = \nu'_j, j = 1, 2, 3$.

The formula for doing step 2 is given by

$$\left. \begin{aligned} C_1 &= 1 \\ C_2 &= -\frac{k_2}{k_3^2} \\ L &= -\frac{k_2^2}{k_4} \\ R &= -\frac{k_2}{k_2} \\ R_0 &= -\frac{k_1 k_3^2}{k_2 k_4} \\ G_a &= -p_1 - \left(\frac{p_2 - q_2}{p_1 - q_1}\right) + \frac{k_2}{k_3} \\ G_b &= -q_1 - \left(\frac{p_2 - q_2}{p_1 - q_1}\right) + \frac{k_2}{k_3} \end{aligned} \right\} \quad (5)$$

where $\{p_1, p_2, p_3, q_1, q_2, q_3\}$ are the “equivalent eigenvalue parameters” defined as

$$\left. \begin{aligned} p_1 &= \mu_1 + \mu_2 + \mu_3 & q_1 &= \nu_1 + \nu_2 + \nu_3 \\ p_2 &= \mu_1 \mu_2 + \mu_2 \mu_3 + \mu_3 \mu_1 & q_2 &= \nu_1 \nu_2 + \nu_2 \nu_3 + \nu_3 \nu_1 \\ p_3 &= \mu_1 \mu_2 \mu_3 & q_3 &= \nu_1 \nu_2 \nu_3 \end{aligned} \right\} \quad (6)$$

and

$$\left. \begin{aligned} k_1 &\triangleq -p_3 + \left(\frac{q_3 - p_3}{q_1 - p_1}\right) \left(p_1 + \frac{p_2 - q_2}{q_1 - p_1}\right) \\ k_2 &\triangleq p_2 - \left(\frac{q_3 - p_3}{q_1 - p_1}\right) + \left(\frac{p_2 - q_2}{q_1 - p_1}\right) \left(\frac{p_2 - q_2}{q_1 - p_1} + p_1\right) \\ k_3 &\triangleq \left(\frac{p_2 - q_2}{q_1 - p_1}\right) - \frac{k_1}{k_2} \\ k_4 &\triangleq -k_1 k_3 + k_2 \left(\frac{p_3 - q_3}{p_1 - q_1}\right) \end{aligned} \right\} \quad (7)$$

The value of E in (2) can be chosen arbitrarily. In terms of the dimensionless parameters, the formulas are:

$$\left. \begin{aligned} \alpha &= \frac{1}{l_1 l_3^2} \\ \beta &= 1 + \frac{1}{l_1^2 l_3^2} \frac{p_3 - q_3}{p_1 - q_1} - \frac{-p_2 + q_2}{p_1 - q_1} \frac{1}{l_1 l_3} \\ \gamma &= -1 + \frac{-p_2 + q_2}{p_1 - q_1} \frac{1}{l_1 l_3} \\ a &= -1 - \left(p_1 + \frac{-p_2 + q_2}{p_1 - q_1} \right) l_3 \\ b &= -1 - \left(q_1 + \frac{-p_2 + q_2}{p_1 - q_1} \right) l_3 \\ k &= \text{sgn}(l_1 l_3) \end{aligned} \right\} \quad (8)$$

where

$$\left. \begin{aligned} l_1 &= -p_2 - \left(\frac{p_2 - q_2}{p_1 - q_1} - p_1 \right) \frac{p_2 - q_2}{p_1 - q_1} + \frac{p_3 - q_3}{p_1 - q_1} \\ l_2 &= -p_3 + \frac{p_3 - q_3}{p_1 - q_1} \left(p_1 + \frac{-p_2 + q_2}{p_1 - q_1} \right) \\ l_3 &= \frac{-p_2 + q_2}{p_1 - q_1} \frac{1}{l_1} + \frac{l_2}{l_1^2} \end{aligned} \right\} \quad (9)$$

II. USING CHUA'S OSCILLATOR TO MODEL OTHER CHAOTIC SYSTEMS

Because of the generality of Chua's oscillator, other chaotic systems can be modelled using Chua's oscillator. The reader is referred to [3], [4] for several examples of circuits and systems belonging to the class \mathcal{C} of vector fields defined above which have been transformed into a "qualitatively similar" Chua's oscillator. These examples include the systems studied by Brockett [5], Nishio [17], Ogorzalek [6], and Sparrow [7]. In this section we will illustrate this procedure with several additional examples.

In the following examples, the system under consideration is either already a 3-D piecewise-linear three-segment continuous odd-symmetric vector field where the partition planes are parallel, or can be approximated by one. When the vector field is not piecewise-linear, we approximate it by calculating the Jacobian matrices at the equilibrium points and using them to define the linear vector field in each region.

We then find the eigenvalues in each linear region and apply algorithm 1 to find the parameters for Chua's oscillator. For cases where the vector field belongs to \mathcal{E}_0 , we perturb the eigenvalues (or equivalent eigenvalue parameters) slightly to obtain a vector field in class $\tilde{\mathcal{C}}$.

2.1. Example from Arnéodo et al.

The systems studied in [8]–[10], satisfy the following differential equation:

$$\ddot{A} + \mu_2 \dot{A} + \mu_1 \dot{A} + \mu_0 A = \pm A^3. \quad (10)$$

In [9], the cubic nonlinearity is replaced by a 3-segment piecewise-linear nonlinearity resulting in a vector field in \mathcal{C} . We have two cases, depending on whether the right hand side is $+A^3$ or $-A^3$.

Case 1 (right hand side is $+A^3$):

$$\left. \begin{aligned} \dot{x} &= y \\ \dot{y} &= z \\ \dot{z} &= x^3 - \mu_0 x - \mu_1 y - \mu_2 z \end{aligned} \right\}. \quad (11)$$

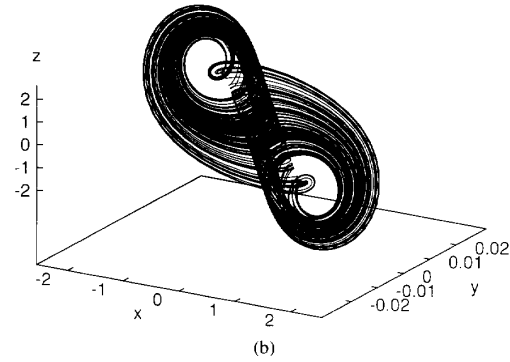
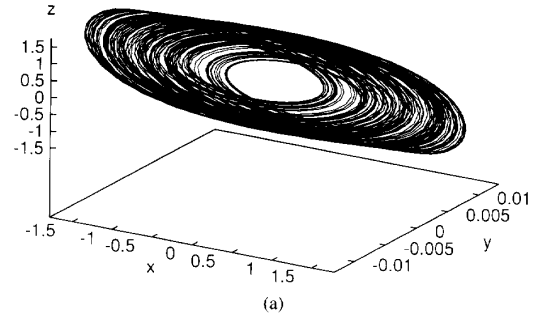

Fig. 1. (a) Strange attractor similar to that generated by $\ddot{A} + \mu_2 \dot{A} + \mu_1 \dot{A} + \mu_0 A = +A^3$; (b) strange attractor similar to that generated by $\ddot{A} + \mu_2 \dot{A} + \mu_1 \dot{A} + \mu_0 A = -A^3$.

The equilibrium points are as follows: $(\sqrt{\mu_0}, 0, 0)$, $(0, 0, 0)$, and $(-\sqrt{\mu_0}, 0, 0)$. From (11), the Jacobian matrix is

$$M = \begin{bmatrix} 0 & 1 & 0 \\ 0 & 0 & 1 \\ 3x^2 - \mu_0 & -\mu_1 & -\mu_2 \end{bmatrix}.$$

We choose $\mu_0 = 9.6$, $\mu_1 = 5$, and $\mu_2 = 1$ and the Jacobian matrix at the equilibrium points in the two outside regions is

$$M = \begin{bmatrix} 0 & 1 & 0 \\ 0 & 0 & 1 \\ 19.2 & -5 & -1 \end{bmatrix}$$

In the inner region the Jacobian matrix at the equilibrium point is:

$$M_0 = \begin{bmatrix} 0 & 1 & 0 \\ 0 & 0 & 1 \\ -9.6 & -5 & -1 \end{bmatrix}$$

As the Jacobian matrix is already in companion form, the corresponding equivalent eigenvalue parameters can be read off directly:

$$\left. \begin{aligned} p_1 &= -1.0, & p_2 &= 5, & p_3 &= -9.6 \\ q_1 &= -1.0, & q_2 &= 5, & q_3 &= 19.2 \end{aligned} \right\}. \quad (12)$$

Since $p_1 = q_1$, this vector field belongs to the set \mathcal{E}_0 . Therefore, we add a small perturbation $\delta p_1 = 0.05$, and $\delta q_1 = -0.05$ to obtain

$$\left. \begin{aligned} p'_1 &= -0.95, & p'_2 &= 5, & p'_3 &= -9.6 \\ q'_1 &= -1.05, & q'_2 &= 5, & q'_3 &= 19.2 \end{aligned} \right\}. \quad (13)$$

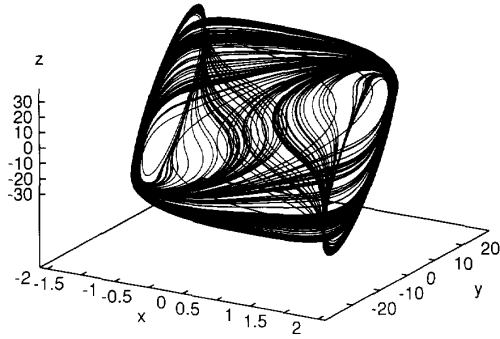

Fig. 2. Strange attractor similar to that generated by circuit proposed by Shinriki *et al.*

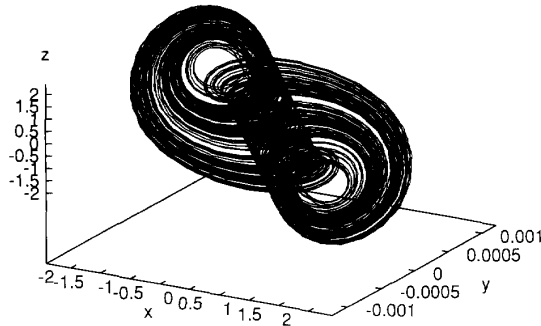

Fig. 3. Strange attractor similar to that generated by circuit proposed by Dmitriev and Kislov.

Substituting (13) into (5) and (8), we obtain the following parameters for the corresponding Chua's oscillator:

$$\left. \begin{aligned} C_1 &= 1.0, & C_2 &= -313.6291, \\ R &= 0.003298815, & R_0 &= 0.00001073564, \\ G_a &= -302.1891, & G_b &= -302.0891 \\ L &= 0.00001110714 \end{aligned} \right\} \quad (14)$$

The corresponding dimensionless parameters are

$$\left. \begin{aligned} \alpha &= -313.6291, & \beta &= -307.2771, & \gamma &= -1, \\ a &= -0.9968661, & b &= -0.9965362, & \tau &= -0.966553, \\ & & k &= -1 \end{aligned} \right\} \quad (15)$$

By using the parameters as above, we obtain the attractor shown in Fig. 1(a), which is qualitatively similar to the attractor in Fig. 1(a) of [10].

Case 2 (right hand side is $-A^3$):

$$\left. \begin{aligned} \dot{x} &= y \\ \dot{y} &= z \\ \dot{z} &= -x^3 - \mu_0 x - \mu_1 y - \mu_2 z \end{aligned} \right\} \quad (16)$$

The equilibrium points are as follows: $(\sqrt{-\mu_0}, 0, 0)$, $(0, 0, 0)$, and $(-\sqrt{-\mu_0}, 0, 0)$.

From (16), the Jacobian matrix is

$$M = \begin{bmatrix} 0 & 1 & 0 \\ 0 & 0 & 1 \\ -3x^2 - \mu_0 & -\mu_1 & -\mu_2 \end{bmatrix}.$$

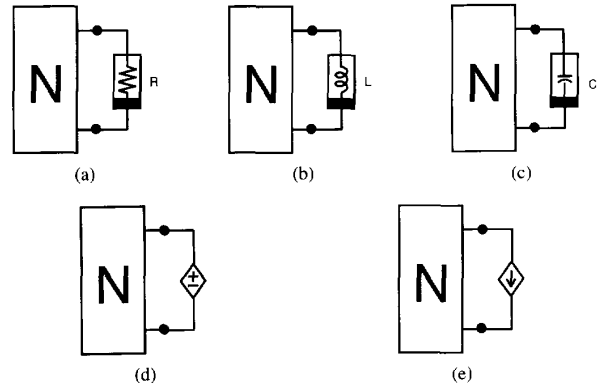

Fig. 4. Five mutually exclusive subclass of circuits belonging to the class C^* that are qualitatively equivalent to Chua's oscillator. The "load" in (a), (b), and (c) is a nonlinear resistor, inductor, and capacitor, respectively. The load in (d) and (e) is a nonlinear controlled voltage source (VCVS or CCVS) or current source (VCCS or CCCS), respectively.

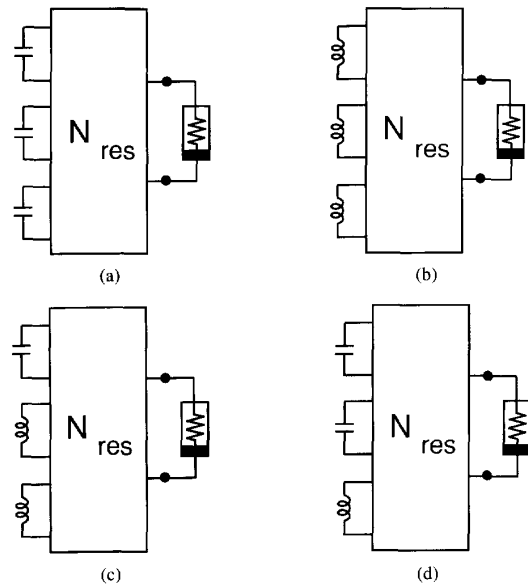

Fig. 5. Circuits belonging to the subclass in Fig. 4(a) can be partitioned into four mutually exclusive groups. The linear four-port N_{res} contains only resistive elements.

We choose $\mu_0 = -5.5$, $\mu_1 = 3.5$, and $\mu_2 = 1.1$, and in the two outside regions the Jacobian matrix at the equilibrium points is

$$M = \begin{bmatrix} 0 & 1 & 0 \\ 0 & 0 & 1 \\ -11 & -3.5 & -1.1 \end{bmatrix}.$$

In the inner region, the Jacobian matrix at the equilibrium point is

$$M_0 = \begin{bmatrix} 0 & 1 & 0 \\ 0 & 0 & 1 \\ 5.5 & -3.5 & -1.1 \end{bmatrix}.$$

TABLE I
FAMILY OF ALL DISTINCT CIRCUITS BELONGING TO THE CLASS C^*
MADE OF TWO LINEAR CAPACITORS, ONE LINEAR INDUCTOR, ONE
NONLINEAR RESISTOR, AND n LINEAR RESISTORS $n = 0, 1, \text{ OR } 2$ (PART I)

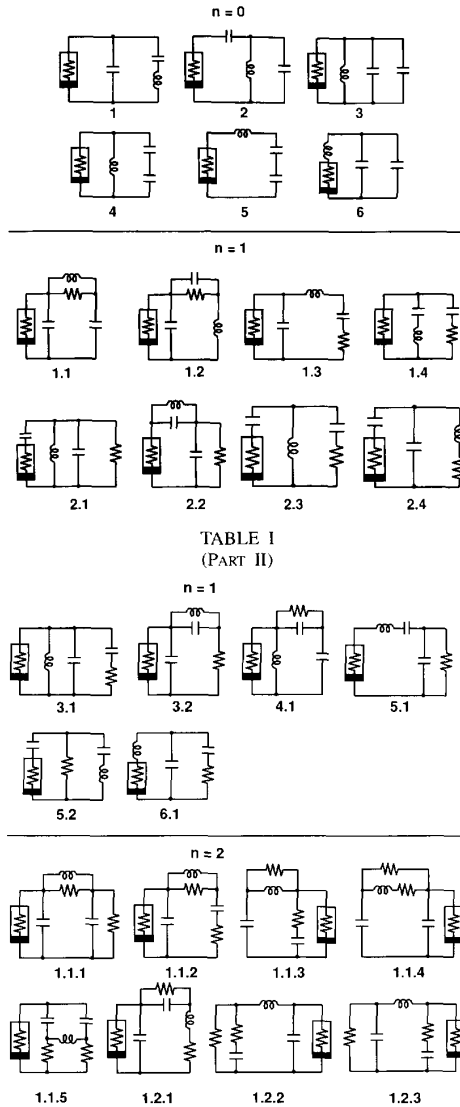
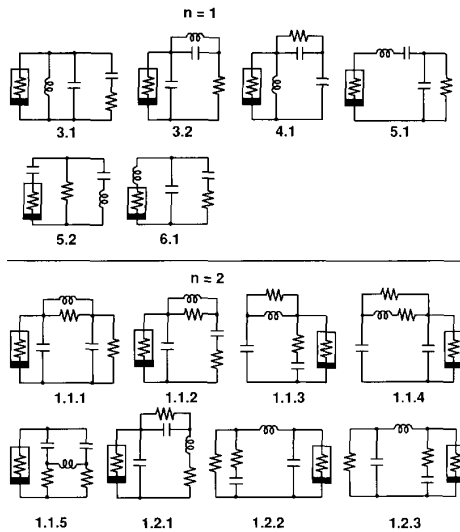

TABLE I
(PART II)



The equivalent eigenvalue parameters are given by

$$\left. \begin{aligned} p_1 &= -1.1, & p_2 &= 3.5, & p_3 &= 5.5 \\ q_1 &= -1.1, & q_2 &= 3.5, & q_3 &= -11.0 \end{aligned} \right\} \quad (17)$$

Now, we add a small perturbation $\delta p_1 = 0.055$, and $\delta q_1 = -0.055$ to obtain

$$\left. \begin{aligned} p'_1 &= -1.045, & p'_2 &= 3.5, & p'_3 &= 5.5 \\ q'_1 &= -1.155, & q'_2 &= 3.5, & q'_3 &= -11.0 \end{aligned} \right\} \quad (18)$$

Substituting (18) into (5) and (8), we obtain the following parameters for the equivalent Chua's oscillator:

$$\left. \begin{aligned} C_1 &= 1.0, & C_2 &= 119.4383, \\ R &= -0.007559785, & R_0 &= 0.000061316, \\ G_a &= 133.3239, & G_b &= 133.4339 \\ L &= 0.0000553641 \end{aligned} \right\} \quad (19)$$

TABLE I
(PART III)

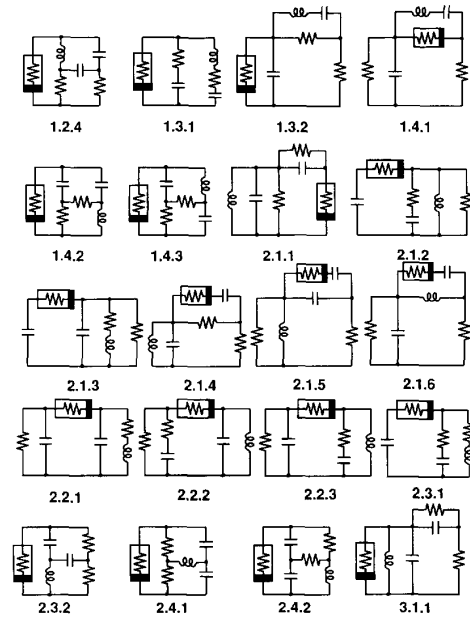
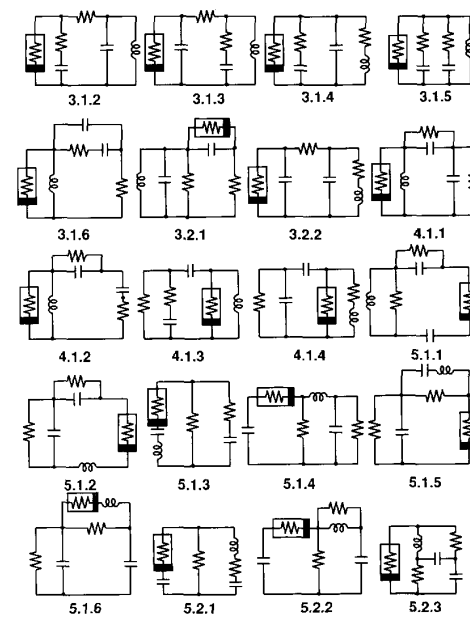

TABLE I
(PART IV)



The corresponding dimensionless parameters are:

$$\left. \begin{aligned} \alpha &= 119.4383, & \beta &= 123.2917, & \gamma &= -0.1, \\ a &= -1.007900, & b &= -1.008732, & \tau &= -1.10751, \\ k &= -1 \end{aligned} \right\} \quad (20)$$

By using the dimensionless parameters above, we obtain the attractor shown in Fig. 1(b), which is qualitatively similar to the attractor in Fig. 1(b) of [10].

TABLE I
(PART V)

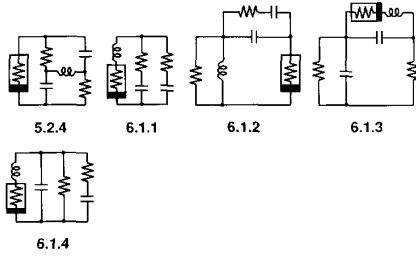

TABLE II
PARAMETER VALUES OF ATTRACTORS IN CHUA'S OSCILLATOR (PART I)

Color plate	α	β	γ	a	δ	k	Lyapunov Exponents
1	9.3515808493	14.7903198054	0.0160739649	-1.1384111956	-0.7224511209	1.0	0.279 0 -2.359
2	-1.550535687	0.0156453445	-0.1574556102	-0.2438532907	-0.0425189943	-1.0	0.03 0 -0.282
3	-1.458906	-0.09307192	-0.32143446	1.218416	-0.5128436	-1.0	0.013 6 -0.617
4	-1.2331692348	0.0072338195	0.0857850597	-0.1547031151	-0.0162669575	-1.0	0.022 6 -0.09
5	-1.5390536687	0.0156453445	0.1574556102	-0.2438532907	-0.0425189943	-1.0	0.03 0 -0.282
6	3.7091002954	24.0799705758	-0.8592556780	-2.7647222013	0.1805569489	1.0	0.368 9 -1.297
7	3.7091002954	24.0799705758	-0.8592556780	-2.7647222013	0.1805569489	1.0	0.368 0 -1.297
8	-6.59191	-1.52061	0.0	-1.142857	-0.7142857	1.0	0.081 0 -0.382
9	142.4037	207.34198	-3.8767721	-0.855372	-1.09956	-1.0	1.22 6 -16.28
10	9.3515908493	14.7903198054	0.0160739649	-1.1384111956	-0.7224511209	1.0	0.279 0 -2.359
11	-4.898979	-3.624135	-0.031180888	-2.591256	-0.9267201	1.0	0.144 0 -1.071
12	-1.438906	-0.09307192	-0.32143446	1.218416	-0.5128436	-1.0	0.013 0 -0.677
13	-6.59191	-1.52061	0.0	-1.142857	-0.7142857	1.0	0.081 9 -0.382
14	-1.3184010525	0.012574900	0.1328593070	-0.2241328978	-0.028101959	-1.0	0.055 0 -0.111
15	-1.301814	-0.0156073	-0.02989968	0.1890817	-0.4787822	1.0	0.012 0 -0.042
16	9.3515908493	14.7903198054	0.0160739649	-1.1384111956	-0.7224511209	1.0	0.279 0 -2.359
17	-1.3635256878	-0.874054928	-3.114345114	1.292156	-4.5717	-1.0	0.028 6 -6.571
18	-1.2331692348	0.0072338195	0.0857850597	-0.1787031151	-0.0162669575	-1.0	0.022 0 -0.09

TABLE II
(PART II)

Color plate	α	β	γ	a	δ	k	Lyapunov Exponents
19	8.4502218418	12.0732335925	0.0051631293	-0.7056296732	-1.1467573476	1.0	0.292 0 -1.451
20	9.572224873	10.897626192	-0.3447440294	-1.1818730745	-0.6523354182	1.0	0.065 6 -1.93
21	4.096	51.45671	-0.93435708	-0.855372	-1.09956	-1.0	0 0 -0.666
22	3.7091002664	24.0799705758	-0.8592556780	-2.7647222013	0.1805569489	1.0	0.368 0 -1.295
23	-4.898979	-3.624135	-0.031180888	-2.591256	-0.9267201	1.0	0.144 0 -1.071
24	-6.68885	-2.0	0.0	-1.142857	-0.7142857	1.0	0.071 0 -0.755
25	-75.0	31.25	-3.125	-98	-2.4	1.0	1.01 0 -68
26	15.6	28.58	0.0	-1.142857	-0.7142857	1.0	0.115 0 -4.82
27	-75.0	31.25	-3.125	-2.4	-98	1.0	0.923 0 -74
28	8.4502218418	12.0732335925	0.0051631293	-0.7056296732	-1.1467573476	1.0	0.292 0 -1.451
29	37.195804	73.04958	-1.161224	-0.855372	-1.09956	-1.0	0.80619 0 -2.67
30	-75.0	31.25	-3.125	-98	-2.4	1.0	1.01 0 -69
31	-1.301814	-0.0156073	-0.02989968	0.1890817	-0.4787822	1.0	0.012 0 -0.042
32	35.939189	75.706831	-1.2033675	-0.855372	-1.09956	-1.0	0 -0.031 -1.73
33	13.070921	53.612166	-0.75087096	-0.855372	-1.09956	-1.0	0.037 0 -0.298
34	45012.877058	-14125.787459626	-0.226802338	-0.999532360	-1.0602837549	1.0	0 0 -1.31
35	9.3515908493	14.7903198054	0.0160739649	-1.1384111956	-0.7224511209	1.0	0.279 0 -2.359
36	3.505	66.672752	-0.94776492	-0.855372	-1.09956	-1.0	0 6 -0.066

TABLE II
(PART III)

Color plate	α	β	γ	a	δ	k	Lyapunov Exponents
37	12.141414	9.771132	-0.8982235	-0.855372	-1.09956	-1.0	0 0 -0.45
38	9.3515908493	14.7903198054	0.0160739649	-1.1384111956	-0.7224511209	1.0	0.279 0 -2.359
39	1800.0	10000.00	0.0	-1.028	-982	1.0	0 0 -0.145
40	-1.7327032212	0.0421158445	0.2973456607	-0.0974632164	-0.2623278484	-1.0	0.042 0 -0.276
41	-1.3184010525	0.012574900	0.1328593070	-0.2241328978	-0.028101959	-1.0	0.035 0 -0.111
42	9.3515908493	14.7903198054	0.0160739649	-1.1384111956	-0.7224511209	1.0	0.279 0 -2.359
43	9.3515908493	14.7903198054	0.0160739649	-1.1384111956	-0.7224511209	1.0	0.279 0 -2.359
44	-2.007961199	0.0013265482	0.0164931244	-0.5112930574	0.0012702165	-1.0	0 -0.00565 -0.602
45	-1.0837792352	0.0009899898	0.0073275247	-0.0941188549	0.0011999298	-1.0	0.0047 0 -0.066

2.2. Examples from Shinriki *et al.*

In the system proposed by Shinriki *et al.* [11] and subsequently studied by Freire *et al.* [12], the circuit consists of four

linear elements and two nonlinear conductances. The nonlinear conductances' v - i characteristics are described by cubic polynomials. The negative nonlinear conductance resembles the v - i characteristic of Chua's diode used in Chua's circuit, in that it can be approximated by a 3-segment piecewise-linear nonlinearity. However, in the parameter region of the chaotic attractor in [11], [12] which we would like to mimic, the chaotic attractor lies in a region of the phase space where the negative nonlinear conductance is monotonically decreasing. Thus the negative conductance is used as a purely active device. We can then approximate the negative nonlinear conductance by a linear negative conductance in the region of interest. The positive nonlinear conductance can be approximated by a 3-segment piecewise-linear characteristic. After these approximations are made we obtain a circuit whose underlying vector field belongs to the class C .

The state equations are written as

$$\left. \begin{aligned} C_0 \frac{dv_1}{dt} &= -G_1 v_1 + a_1 v_1 - a_3 v_1^3 \\ &\quad + b_1 (v_2 - v_1) + b_3 (v_2 - v_1)^3 \\ C \frac{dv_2}{dt} &= -i_L - G_2 v_2 - b_1 (v_2 - v_1) \\ &\quad - b_3 (v_2 - v_1)^3 \\ L \frac{di_L}{dt} &= v_2 \end{aligned} \right\} \quad (21)$$

From (21), the three equilibria are $(0, 0, 0)$ and $(\pm \bar{x}, \pm \bar{y}, \pm \bar{z})$, where

$$\left. \begin{aligned} \pm \bar{x} &= \pm \left(\frac{-\mu}{a_3 + b_3} \right)^{1/2} \\ \pm \bar{y} &= 0 \\ \pm \bar{z} &= \pm (b_1 \bar{x} + b_3 \bar{x}^3) \end{aligned} \right\} \quad (22)$$

At the equilibrium point $(0, 0, 0)$ the Jacobian matrix is

$$J(0, 0, 0) = \begin{bmatrix} -\frac{G_1 + b_1 - a_1}{C_0} & \frac{b_1}{C_0} & 0 \\ \frac{b_1}{C} & -\frac{b_1 + G_2}{C} & -\frac{1}{C} \\ 0 & \frac{1}{L} & 0 \end{bmatrix} \quad (23)$$

and at the equilibrium points $(\pm \bar{x}, \pm \bar{y}, \pm \bar{z})$ the Jacobian matrix is

$$J(\pm \bar{x}, \pm \bar{y}, \pm \bar{z}) = \begin{bmatrix} \frac{2\mu}{C_0} & \frac{b_1 - q\mu}{C_0} & 0 \\ \frac{b_1 - q\mu}{C} & -\frac{\delta - q\mu}{C} & -\frac{1}{C} \\ 0 & \frac{1}{L} & 0 \end{bmatrix} \quad (24)$$

where

$$\mu = G_1 + b_1 - a_1, \quad \delta = G_2 + b_1, \quad q = \frac{3b_3}{a_3 + b_3}. \quad (25)$$

When we choose $C = 0.1\mu F$, $L = \frac{1}{6}H$, $C_0 = 4.7nF$, $G_2 = 3.813851\mu S$, $a_1 = 11 \times 10^{-5}$, $b_1 = 1.52554 \times 10^{-5}$, $a_3 = 5.7210 \times 10^{-6}$, $b_3 = 4.76731 \times 10^{-5}$, and $R_1 = \frac{1}{G_1} = 38k\Omega$, then

$$J(0, 0, 0) = \begin{bmatrix} 14559.32 & 3245.83 & 0 \\ 152.55 & -190.69 & -10000000 \\ 0 & 6 & 0 \end{bmatrix} \quad (26)$$

$$J(\pm \bar{x}, \pm \bar{y}, \pm \bar{z}) = \begin{bmatrix} -29118.6428 & 42243.846 & 0 \\ 1985.461 & -2023.5993 & -10000000 \\ 0 & 6 & 0 \end{bmatrix} \quad (27)$$

The corresponding eigenvalues are

$$\left. \begin{aligned} \mu_1 &= 14.5855, \\ \mu_2 &= -0.108453 + j7.73824, \\ \mu_3 &= -0.108453 - j7.73824 \\ \nu_1 &= -31.7699, \\ \nu_2 &= 0.313848 + j7.40907, \\ \nu_3 &= 0.313848 - j7.40907 \end{aligned} \right\} \quad (28)$$

Converting (28) into equivalent eigenvalue parameters and using (5) and (8), we obtain the following parameters for the equivalent Chua's oscillator:

$$\left. \begin{aligned} C_1 &= 1.0, & C_2 &= 0.0700946, & L &= 0.089575 \\ R &= -1.381763, & R_0 &= 0.882183, \\ G_a &= -13.16857, & G_b &= 32.34223 \end{aligned} \right\} \quad (29)$$

and the dimensionless parameters

$$\left. \begin{aligned} \alpha &= 0.0700946, & \beta &= 1.49404, & \gamma &= -0.953867, \\ a &= 18.19584, & b &= -44.6893, & \tau &= 10.3248, \\ & & k &= -1 \end{aligned} \right\} \quad (30)$$

By using the parameters above, we obtain the attractor shown in Fig. 2, which is qualitatively similar to the corresponding attractor given in Fig. 15(a) of [12].

2.3. Example from Dmitriev and Kislov

In the oscillator system studied in [13]–[15], the nonlinearity is a cubic polynomial which becomes constant in an outer region. This can again be approximated by a piecewise-linear function if we ignore the outer region.

The state equations are

$$\left. \begin{aligned} \dot{x} &= y \\ \dot{y} &= -x - \delta y + z \\ \dot{z} &= \gamma(F(x) - z) - \sigma y \end{aligned} \right\} \quad (31)$$

where

$$F(x) = \begin{cases} 0.528\alpha & \text{if } x < -1.2 \\ \alpha x(1 - x^2) & \text{if } -1.2 \leq x \leq 1.2 \\ -0.528\alpha & \text{if } x > 1.2 \end{cases} \quad (32)$$

The equilibrium points are given by

$$\left. \begin{aligned} y &= 0 \\ -x - \delta y + z &= 0 \\ \gamma(F(x) - z) - \sigma y &= 0 \end{aligned} \right\} \quad (33)$$

1) when $x < -1.2$, then

$$\left. \begin{aligned} y &= 0 \\ -x - \delta y + z &= 0 \\ \gamma(0.528\alpha - z) - \sigma y &= 0 \end{aligned} \right\} \quad (34)$$

so we have

$$\left. \begin{aligned} x &= 0.528\alpha \quad \left(\alpha = \frac{x}{0.528} < \frac{-1.2}{0.528} = -2.2727\right) \\ y &= 0 \\ z &= 0.528\alpha \end{aligned} \right\} \quad (35)$$

2) when $-1.2 < x < 1.2$, then

$$\left. \begin{aligned} y &= 0 \\ -x - \delta y + z &= 0 \\ \gamma(\alpha x(1 - x^2) - z) - \sigma y &= 0 \end{aligned} \right\} \quad (36)$$

therefore, we have $x = 0$, $x = \pm \sqrt{\frac{\alpha-1}{\alpha}}$, for $\alpha \geq 1$.

The three equilibrium points are $(\sqrt{\alpha-1}, 0, \sqrt{\alpha-1})$, $(0, 0, 0)$, and $(-\sqrt{\frac{\alpha-1}{\alpha}}, 0, -\sqrt{\frac{\alpha-1}{\alpha}})$.

3) when $x > 1.2$

$$\left. \begin{aligned} y &= 0 \\ -x - \delta y + z &= 0 \\ \gamma(-0.528 - z) - \sigma y &= 0 \end{aligned} \right\} \quad (37)$$

so we have

$$\left. \begin{aligned} x &= -0.528\alpha \quad \left(\alpha = \frac{x}{-0.528} < \frac{-1.2}{-0.528} = -2.2727\right) \\ y &= 0 \\ z &= -0.528\alpha \end{aligned} \right\} \quad (38)$$

We will consider values of α where there are no equilibrium points in the outer regions ($|x| > 1.2$). From (31), at the origin the Jacobian matrix is

$$M_0 = \begin{bmatrix} 0 & 1 & 0 \\ -1 & -\delta & 1 \\ \alpha\gamma & -\sigma & -\gamma \end{bmatrix}$$

At the two other equilibrium points, the Jacobian matrix is

$$M_{\pm} = \begin{bmatrix} 0 & 1 & 0 \\ -1 & -\delta & 1 \\ \alpha\gamma \left[1 - 3\left(\sqrt{\frac{\alpha-1}{\alpha}}\right)^2\right] & -\sigma & -\gamma \end{bmatrix}$$

Let $\alpha = 16$, $\delta = 0.43$, $\sigma = 0.71$, and $\gamma = 0.1$. We have

$$M_{\pm} = \begin{bmatrix} 0 & 1 & 0 \\ -1 & -0.43 & 1 \\ -2.9 & -0.71 & -0.1 \end{bmatrix}$$

with eigenvalues:

$$\left. \begin{aligned} \nu_1 &= -1.18562, & \nu_2 &= 0.3278 + j1.5566, \\ \nu_3 &= 0.3278 - j1.5566 \end{aligned} \right\} \quad (39)$$

and

$$M_0 = \begin{bmatrix} 0 & 1 & 0 \\ -1 & -0.43 & 1 \\ 1.6 & -0.71 & -0.1 \end{bmatrix}$$

with eigenvalues

$$\left. \begin{aligned} \mu_1 &= 0.61184, & \mu_2 &= -0.57095 + j1.45797, \\ \mu_3 &= -0.57095 - j1.45797. \end{aligned} \right\} \quad (40)$$

Therefore, the corresponding equivalent eigenvalue parameters are given by

$$\left. \begin{aligned} p_1 &= -0.53006, & p_2 &= 1.7530, & p_3 &= 1.500024 \\ q_1 &= -0.53002, & q_2 &= 1.753164, & q_3 &= -3.00016 \end{aligned} \right\} \quad (41)$$

Again, we add a small perturbation, $\delta p_1 = 0.00265$, $\delta q_1 = -0.00265$ to obtain

$$\left. \begin{aligned} p'_1 &= -0.52741, & p'_2 &= 1.7530, & p'_3 &= 1.500024 \\ q'_1 &= -0.53267, & q'_2 &= 1.753164, & q'_3 &= -3.00016 \end{aligned} \right\} \quad (42)$$

These equivalent eigenvalues correspond to the following set

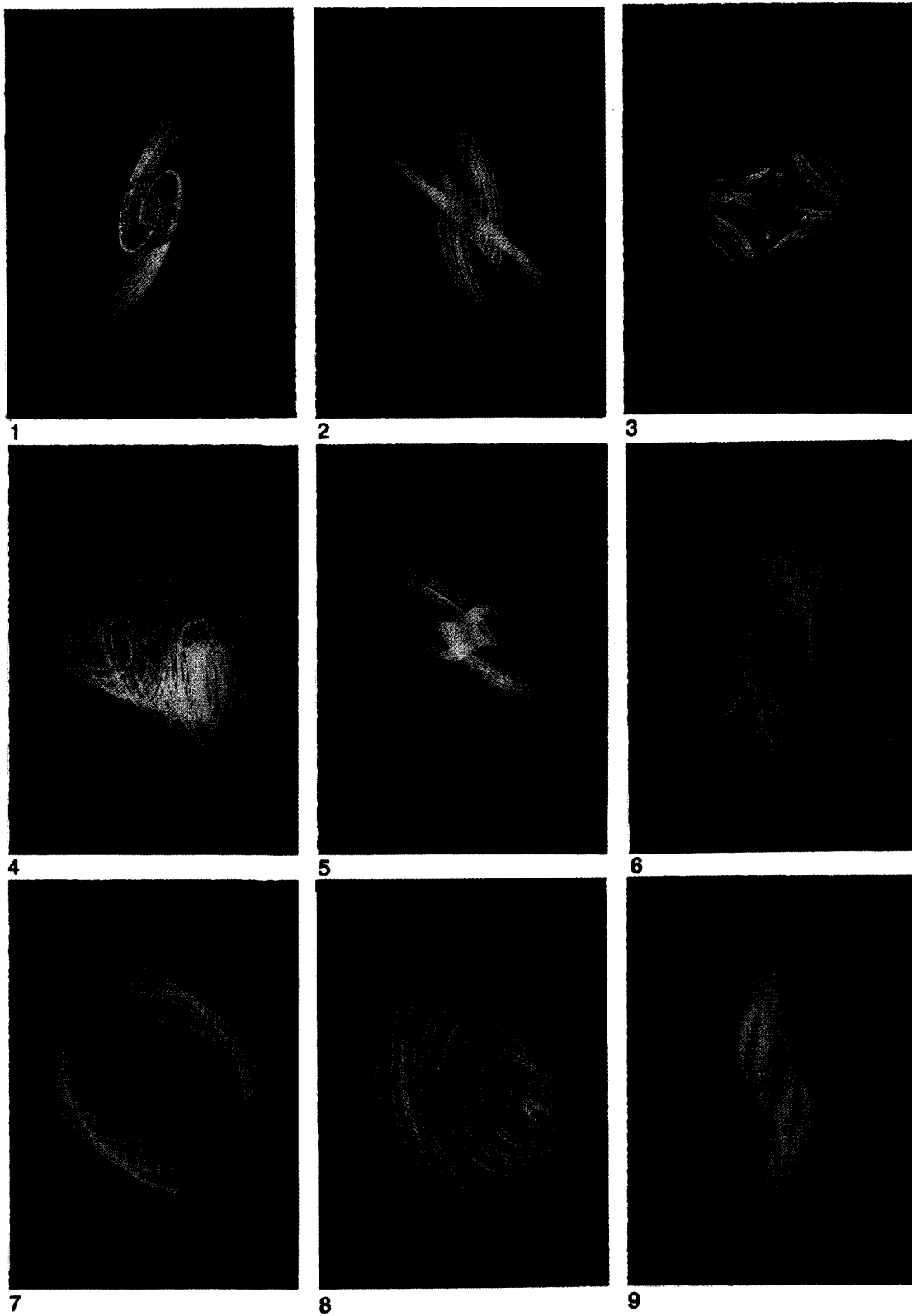

Fig. 6. Attractors: color plates 1–9.

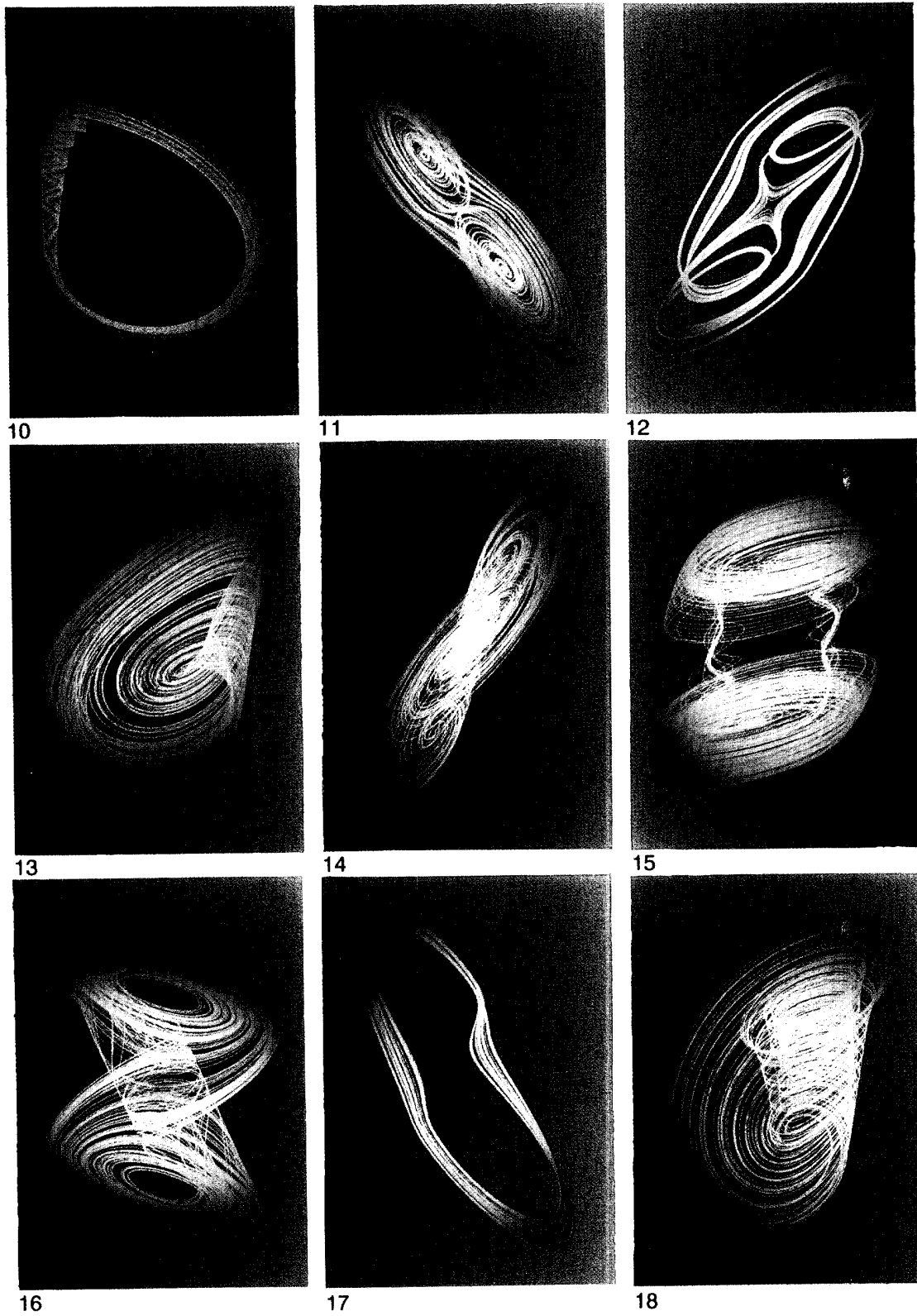

Fig. 7. Attractors: color plates 10-18.

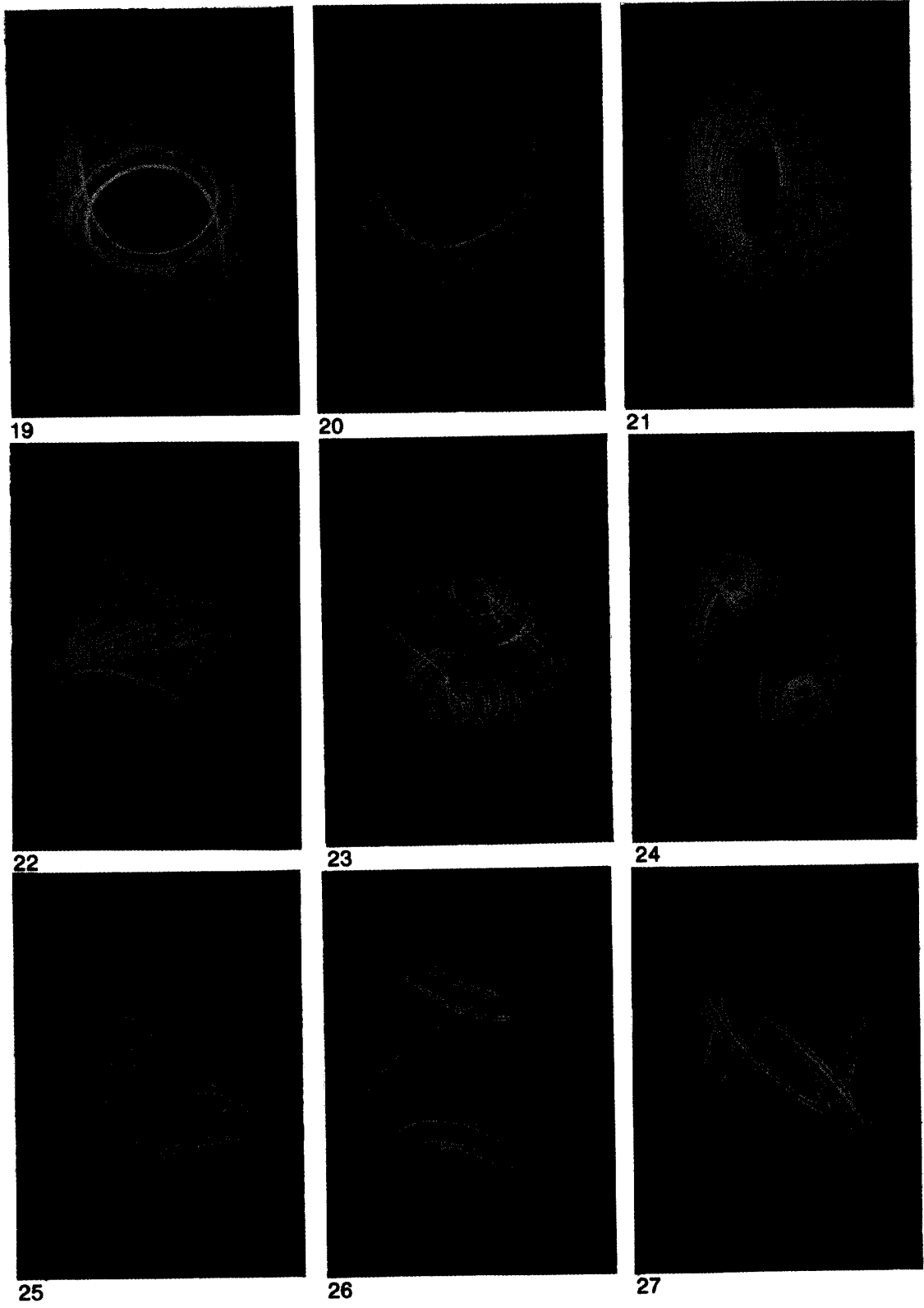

Fig. 8. Attractors: color plates 19–27.

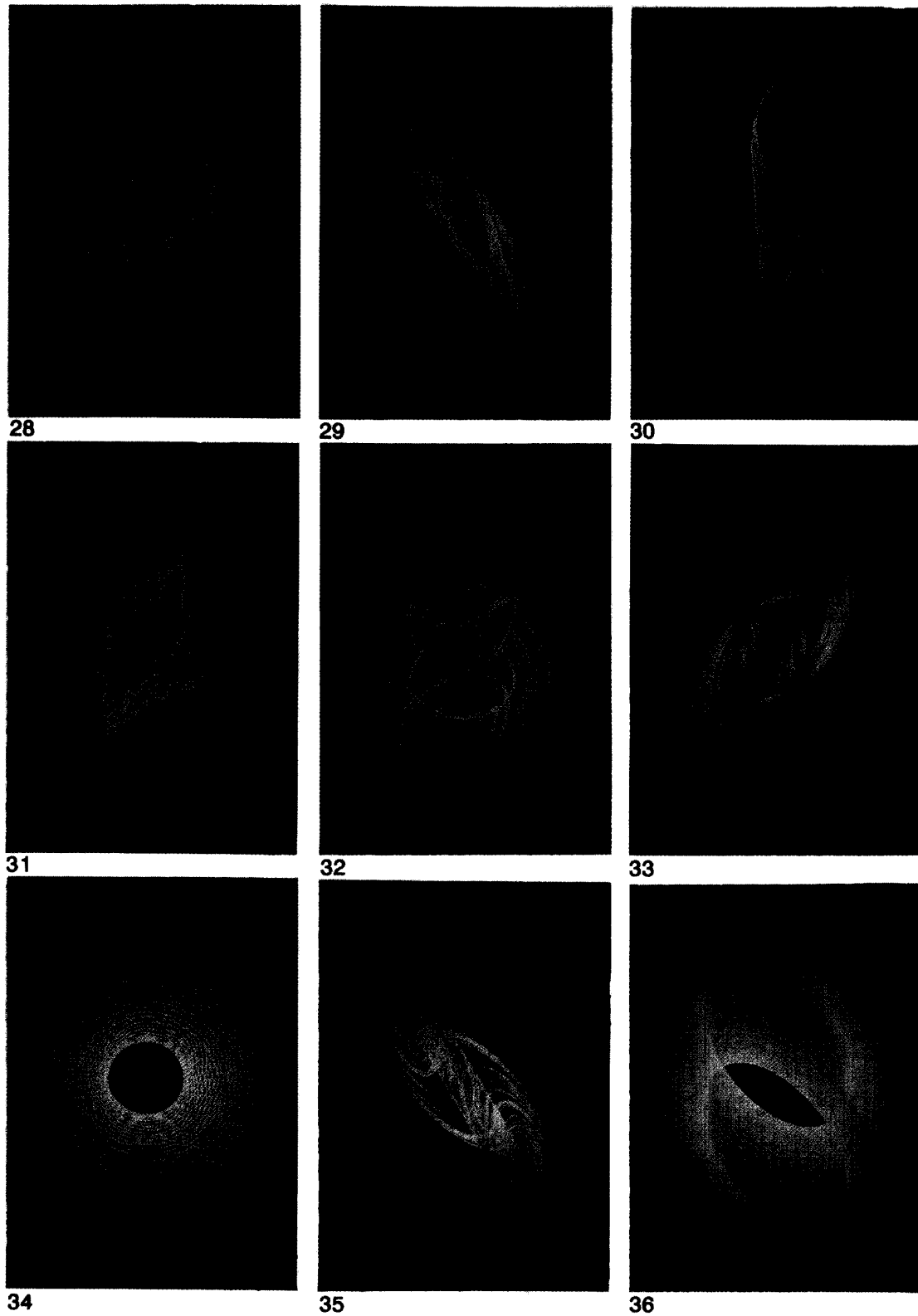

Fig. 9. Attractors: color plates 28–36.

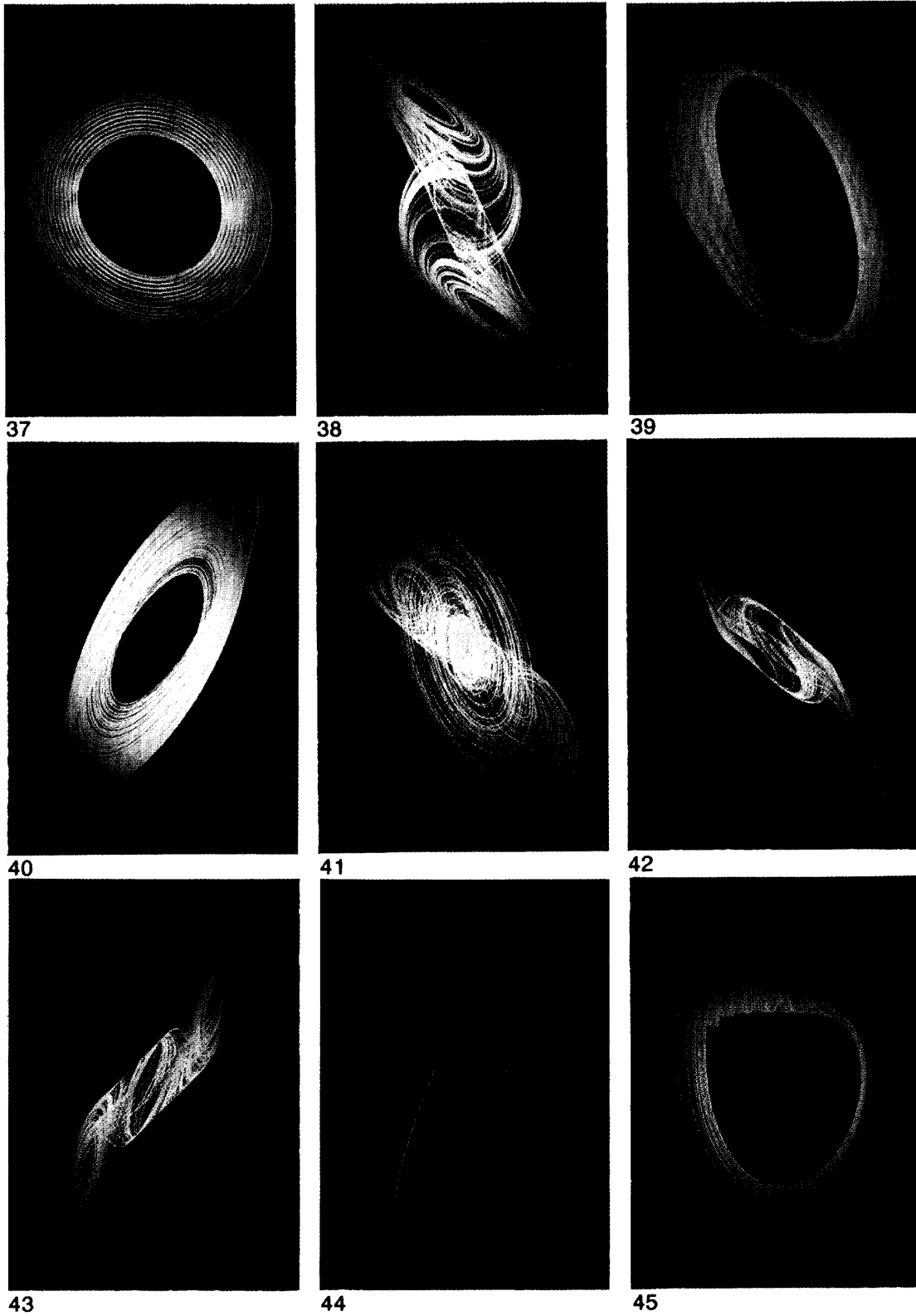

Fig. 10. Attractors: color plates 37–45.

TABLE AI

System in C	A_0	Eigenvalues of A_0	A	Eigenvalues of A	b	Init. cond.	Lyp. Exp.
Brockett [5]	$\begin{pmatrix} 0 & 1 & 0 \\ 0 & 0 & 1 \\ 1.8 & -1.25 & -1 \end{pmatrix}$	0.7220 $-0.8610 \pm 1.3236j$	$\begin{pmatrix} 0 & 1 & 0 \\ 0 & 0 & 1 \\ -3.6 & -1.25 & -1 \end{pmatrix}$	-1.6111 $0.3055 \pm 1.4633j$	$\begin{pmatrix} 0 \\ 0 \\ 5.4 \end{pmatrix}$	1.404 -1.543 -0.736	0.102 0 -1.102
Ogorzalek [6]	$\begin{pmatrix} -1 & 1 & 0 \\ 1 & -2 & 1 \\ -33.03 & 1 & -2 \end{pmatrix}$	-5.1249 $0.0625 \pm 2.576j$	$\begin{pmatrix} -1 & 1 & 0 \\ 1 & -2 & 1 \\ 400 & 1 & -2 \end{pmatrix}$	5.8054 $-5.4027 \pm 6.2881j$	$\begin{pmatrix} 0 \\ 0 \\ -433.03 \end{pmatrix}$	-0.523 -2.543 -0.736	0.291 0 -5.29
Sparrow [7]	$\begin{pmatrix} -1 & 1 & 0 \\ 0 & -1 & 1 \\ -8.4 & 0 & -1 \end{pmatrix}$	-3.0328 $0.0164 \pm 1.7605j$	$\begin{pmatrix} -1 & 1 & 0 \\ 0 & -1 & 1 \\ 159.6 & 0 & -1 \end{pmatrix}$	4.4243 $-3.7122 \pm 4.6976j$	$\begin{pmatrix} 0 \\ 0 \\ -168 \end{pmatrix}$	-0.854 0.086 3.504	0.204 0 -3.204
Dmitriev and Kislov [13]	$\begin{pmatrix} 0 & 1 & 0 \\ -1 & -0.43 & 1 \\ 1.6 & -0.71 & -0.1 \end{pmatrix}$	0.6118 $-0.5709 \pm 1.4580j$	$\begin{pmatrix} 0 & 1 & 0 \\ -1 & -0.43 & 1 \\ -2.9 & -0.71 & -0.1 \end{pmatrix}$	-1.1856 $0.3278 \pm 1.5566j$	$\begin{pmatrix} 0 \\ 0 \\ 4.5 \end{pmatrix}$	0.046 -2.213 0.546	0.132 0 -0.662
Arneodo [9,10]	$\begin{pmatrix} 0 & 1 & 0 \\ 0 & 0 & 1 \\ -9.6 & -5 & -1 \end{pmatrix}$	-1.6067 $0.3034 \pm 2.4255j$	$\begin{pmatrix} 0 & 1 & 0 \\ 0 & 0 & 1 \\ 19.2 & -5 & -1 \end{pmatrix}$	1.8603 $-1.4301 \pm 2.8767j$	$\begin{pmatrix} 0 \\ 0 \\ -28.8 \end{pmatrix}$	0.819 1.299 -5.272	0.3 0 -1.3
Arneodo [9,10]	$\begin{pmatrix} 0 & 1 & 0 \\ 0 & 0 & 1 \\ 5.5 & -3.5 & -1.1 \end{pmatrix}$	0.9884 $-1.0442 \pm 2.1152j$	$\begin{pmatrix} 0 & 1 & 0 \\ 0 & 0 & 1 \\ -11 & -3.5 & -1.1 \end{pmatrix}$	-2.0355 $0.4677 \pm 2.2771j$	$\begin{pmatrix} 0 \\ 0 \\ 16.5 \end{pmatrix}$	0.625 0.481 1.472	0.16 0 -1.36
Nishio [17]	$\begin{pmatrix} 0.5 & 0 & -1 \\ 0 & 0 & 1 \\ 0.5 & -1 & -0.7 \end{pmatrix}$	0.3679 $-0.284 \pm 1.1306j$	$\begin{pmatrix} -10 & 0 & -1 \\ 0 & 0 & 1 \\ -10 & -1 & -0.7 \end{pmatrix}$	-10.9656 $0.1328 \pm 0.9457j$	$\begin{pmatrix} 10.5 \\ 0 \\ 10.5 \end{pmatrix}$	1.046 -0.839 0.118	0.082 0 -7.25

TABLE AII

System in C	Corresponding $\begin{pmatrix} \alpha & \beta & \gamma \\ a & b & k \end{pmatrix}$	Eigenvalues in D_0	Eigenvalues in D_{\pm}	\bar{T}	Init. Cond.	Lyp. Exp.
Brockett	$\begin{pmatrix} 52.566 & 54.813 & -1.00264 \\ -1.018 & -1.020 & -1 \end{pmatrix}$	0.7265 $-0.8377 \pm j1.3275$	-1.6808 $0.3134 \pm j1.484$	$\begin{pmatrix} 1 & 0 & 0 \\ -1.046 & -52.566 & 0 \\ 53.66 & 2.4245 & 52.566 \end{pmatrix}$	-0.748 0.019 0.768	0.081 0 -1.07
Ogorzalek	$\begin{pmatrix} -353.79 & -352.543 & -1.00267 \\ -0.997166 & -0.997138 & -1 \end{pmatrix}$	-1.0108 $0.0027 \pm j0.5025$	1.1650 $-1.0901 \pm j1.2644$	$\begin{pmatrix} 1 & 0 & 0 \\ -0.0125 & 353.79 & 0 \\ -353.48 & 1056.9 & -353.79 \end{pmatrix}$	-0.95 -0.00215 0.9472	0.056 0 -1.063
Sparrow	$\begin{pmatrix} -316.7848 & -315.445 & -0.9996863 \\ -0.9968445 & -0.9967806 & -1 \end{pmatrix}$	-1.0162 $0.0084 \pm j0.5973$	1.4865 $-1.2530 \pm j1.5796$	$\begin{pmatrix} 1 & 0 & 0 \\ -0.0199 & 316.785 & 0 \\ -316.7844 & 627.2792 & -316.7848 \end{pmatrix}$	-0.635 -0.0033 0.632	0.083 0 -1.084
Dmitriev and Kislov	$\begin{pmatrix} 3768.076 & 3776.806 & -1.056794 \\ -1.000279 & -1.000282 & -1 \end{pmatrix}$	1.2039 $-1.1560 \pm j3.0299$	-2.5957 $0.7382 \pm j3.3198$	$\begin{pmatrix} 1 & 0 & 0 \\ -1.1 & -3768.1 & 0 \\ 3769.7 & -1384.4 & 3768.1 \end{pmatrix}$	1.871269 -0.000437 -1.873547	0.26 0 -1.38
Arneodo	$\begin{pmatrix} -313.1022 & -306.7586 & -0.9996019 \\ -0.9968621 & -0.9965319 & -1 \end{pmatrix}$	-1.6476 $0.3327 \pm j2.5158$	1.9136 $-1.4995 \pm j2.9722$	$\begin{pmatrix} 1 & 0 & 0 \\ -1.0859 & 313.1022 & 0 \\ -311.9231 & -26.8860 & -313.1022 \end{pmatrix}$	0.9212 0.008536 -0.90295	0.27 0 -1.29
Arneodo	$\begin{pmatrix} 118.0615 & 121.8824 & -0.9971798 \\ -1.00797 & -1.008807 & -1 \end{pmatrix}$	0.8933 $-0.9157 \pm j1.9023$	-1.846 $0.4045 \pm j2.0373$	$\begin{pmatrix} 1 & 0 & 0 \\ -1.0398 & -118.0615 & 0 \\ 119.1426 & 4.6950 & 118.0615 \end{pmatrix}$	1.2255 0.0056 -1.239	0.166 0 -1.158
Nishio	$\begin{pmatrix} -0.03258462 & 1.207525 & -1.098891 \\ -6.058885 & -112.264 & 1 \end{pmatrix}$	0.1213 $-0.0936 \pm j0.3726$	-3.6141 $0.0438 \pm j0.3117$	$\begin{pmatrix} 1 & 0 & 0 \\ -28.6812 & -0.1979 & -0.0326 \\ -6.3745 & 0.0326 & 0 \end{pmatrix}$	0.63069 3.21152 4.15898	0.026 0 -2.39

of perturbed eigenvalues:

$$\left. \begin{aligned} \mu'_1 &= 0.612122, \\ \mu'_2 &= -0.569766 + j1.45805, \\ \mu'_3 &= -0.569766 - j1.45805 \\ \nu'_1 &= -1.18641, \\ \nu'_2 &= 0.326871 + j1.55625, \\ \nu'_3 &= 0.326871 - j1.55625 \end{aligned} \right\} \quad (43)$$

Substituting (42) into (5) and (8), we obtain the following parameters for Chua's oscillator:

$$\left. \begin{aligned} C_1 &= 1.0, & C_2 &= 3768.076, \\ R &= -5.5741e - 4, & R_0 &= 1.5597e - 7, \\ G_a &= 1794.501, & G_b &= 1794.506 \\ L &= 3.099916e - 7, \end{aligned} \right\} \quad (44)$$

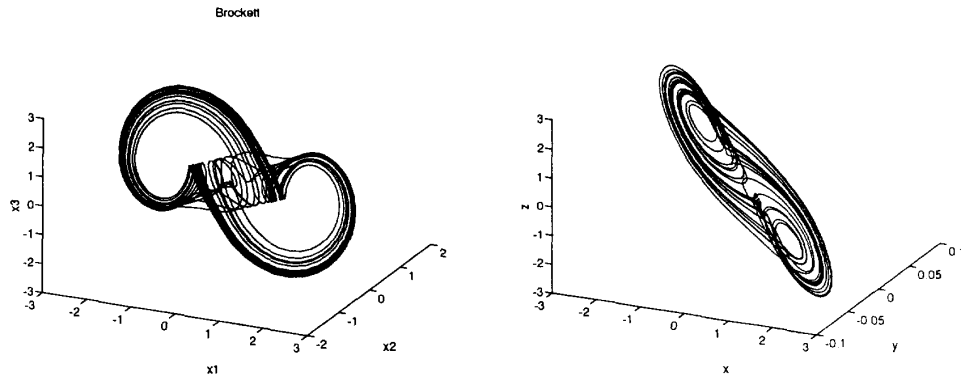

Fig. A1.

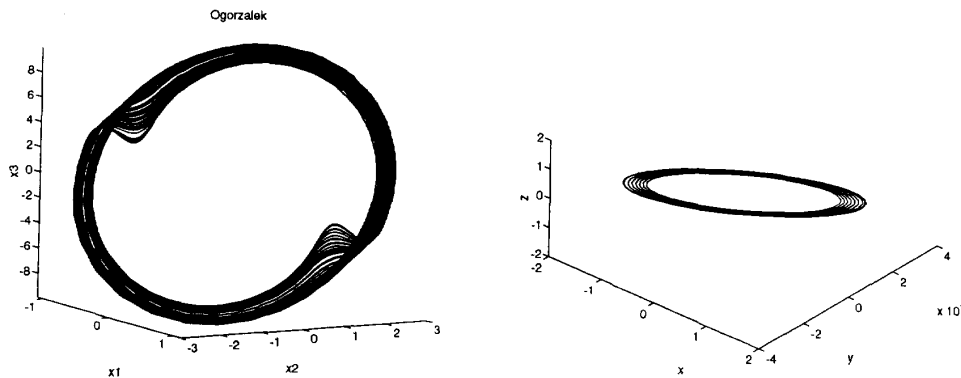

Fig. A2.

The corresponding dimensionless parameters are

$$\left. \begin{aligned} \alpha &= 3768.076, & \beta &= 3776.806, & \gamma &= -1.056794, \\ a &= -1.000279, & b &= -1.000282, & \tau &= 0.4761051, \\ & & k &= -1 \end{aligned} \right\} \quad (45)$$

By using the dimensionless parameters above, we obtain the attractor shown in Fig. 3.

III. FAMILY \mathcal{C}^* OF CIRCUITS QUALITATIVELY EQUIVALENT TO CHUA'S OSCILLATOR

Let us denote by \mathcal{C}^* the family of all piecewise-linear circuits which can be transformed to Chua's oscillator by the procedure illustrated in the preceding section II. Since in general a *small* perturbation in the eigenvalue parameters associated with a circuit belonging to \mathcal{C}^* may be needed to establish topological conjugacy with Chua's oscillator, we can only claim the *qualitative properties* of its dynamics are *similar* to Chua's oscillator, a fact guaranteed by the continuous dependence of the solutions of the associated ODE on initial conditions and parameters. To emphasize this "weaker" concept of equivalence, we will henceforth define any circuit belonging to the class \mathcal{C}^* as *qualitatively equivalent* to Chua's oscillator. If a particular circuit belonging to \mathcal{C}^*

requires no perturbation in the eigenvalue parameters, then it is said to be *topologically conjugate* to Chua's oscillator.

The family of all circuits belonging to the class \mathcal{C}^* can be classified into one of the five subclasses shown in Fig. 4, where the only *nonlinear* element had been extracted as a "load" connected across a *linear time-invariant* one-port N . Each two-terminal nonlinear element in Fig. 4(a)–(c) and each nonlinear controlled source in Fig. 4(d) and (e) is characterized by an odd-symmetric three-segment continuous piecewise-linear function. The one-port N may contain only *linear* time-invariant elements, possibly *multiterminal* (e.g., linear controlled sources, multi-port transformers, etc.) and *nonreciprocal* (e.g., gyrators, circulators, etc.). Since the number of circuit elements inside N can be arbitrarily large, and since these elements can be interconnected in a great variety of distinct topologies, the universe of all nonlinear circuits which are qualitatively equivalent to Chua's oscillator is enormously large. For example, the subclass in Fig. 4(a) can be further classified into four groups as shown in Fig. 5, where N_{res} is a resistive four-port.

If the elements inside the four-port N consist of only two-terminal linear resistors, then in principle, we can apply the classic *star-mesh transformation* to reduce the number of resistors considerably by eliminating all *internal* nodes of the four-port. In this special case, it is possible to enumerate sys-

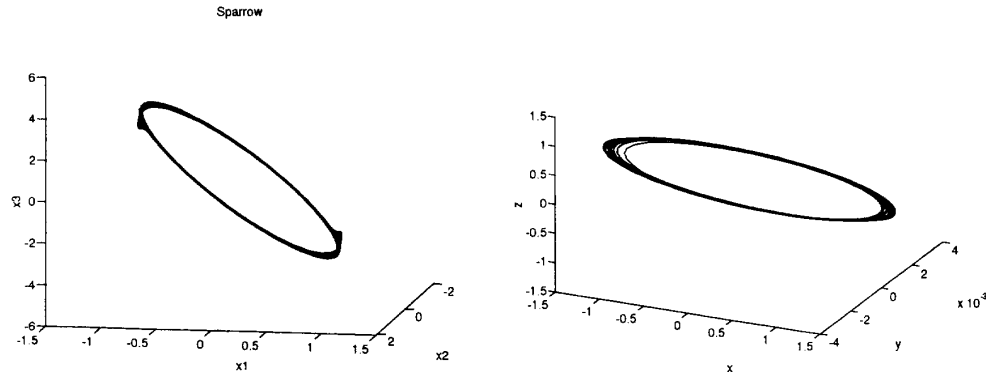

Fig. A3.

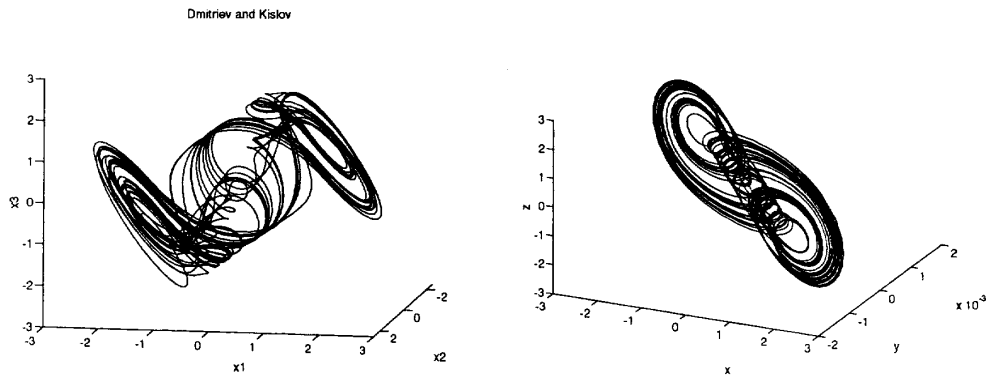

Fig. A4.

tematically all distinct members of this subclass. For example, Table I enumerates all such circuits belonging to group (d) in Fig. 5 where the resistive four-port N_{res} contains only $n = 0, 1,$ or 2 linear two-terminal resistors and connecting wires. The number of circuits becomes large when n is greater than 2 , and in [3], it was shown that $n = 2$ is sufficient for the resulting circuit to be canonical.

Each circuit in Table I is coded by a decimal numbering in order to identify its "genealogy." Each integer added corresponds to adding a linear resistor to an earlier generated circuit. For example, the circuit coded by the number (1.1.3) is obtained by adding a linear resistor to the circuit coded with (1.1). Since five such *distinct* circuits are possible, the parent circuit (1.1) gives rise to five off-springs (1.1.1), (1.1.2), (1.1.3), (1.1.4), and (1.1.5). Hence, each newly generated circuit can be interpreted as mathematically equivalent to an "unfolding" of its parent circuit. Note that for the last four circuits in Table I for the case $n = 0$, two capacitors in series, or in parallel, can be replaced by one capacitor, resulting in a simpler circuit. However, these circuits can spawn new circuits by adding a new linear resistor and therefore they are listed in Table I in their "unreduced" form. In addition, note that some circuits can have more than one parent circuit. In Table I, Chua's circuit has the code 3.2 and Chua's oscillator has the code 3.2.2.

IV. A GALLERY OF ATTRACTORS FROM CHUA'S OSCILLATOR

In this section, we give a gallery of color pictures of attractors found in Chua's oscillator (see Figs. 6–10). For pedagogical reasons, some of the attractors are shown in several different perspectives. The dimensionless parameter values are given in Table II. The attractors were generated by integrating the differential equations using a fourth-order Runge-Kutta method and allowing the transient to settle. The initial conditions are chosen near the origin, except for cases where there are several nontrivial coexisting attractors in the state space, in which case, the initial conditions are chosen in the basin of attraction of the attractor. For example, the initial conditions for color plate 26 is $x_0 = 1.8$, $y_0 = 0.18$, and $z_0 = -1.88$.

The three Lyapunov exponents corresponding to the attractor, which are computed numerically and listed in decreasing order in Table II, form a measure of the rate of divergence of trajectories starting from neighboring initial conditions. The Lyapunov exponents can also tell us the type of attractor to which they correspond. For example, one of the Lyapunov exponent of a chaotic attractor is positive which implies sensitive dependence on initial conditions, while a limit cycle has two negative Lyapunov exponents and one zero Lyapunov exponent [16]. It has also been shown by Haken that for

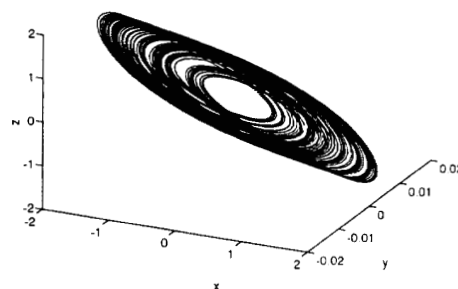
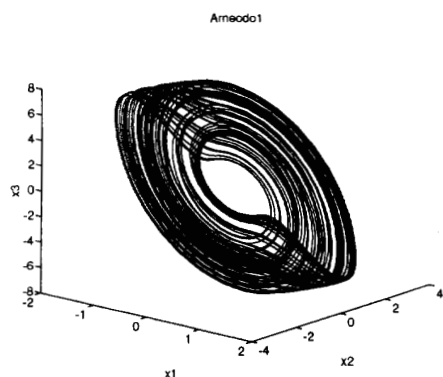

Fig. A5.

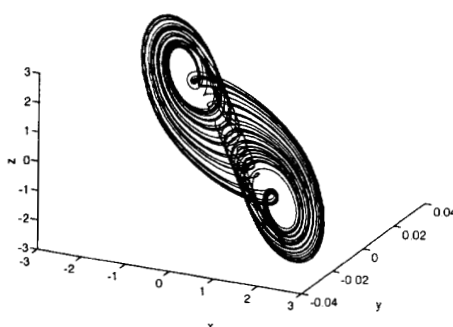
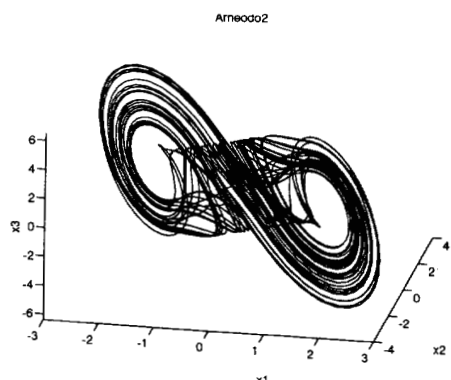

Fig. A6.

systems with a finite number of equilibrium points, any bounded attractor which is not an equilibrium point must have one Lyapunov exponent equal to zero [16].

V. ABC: SOFTWARE FOR SIMULATING CHUA'S OSCILLATOR

For readers who are interested in experimenting with Chua's oscillator, there is a PC-based software package available called *Adventures in Bifurcation and Chaos* (ABC). This is a continuously evolving program written by M. P. Kennedy and C. W. Wu and future versions of the software will be maintained by M. P. Kennedy. Interested readers can send a request for a complimentary copy of ABC to

Dr. Michael Peter Kennedy
Department of Electronic and Electrical Engineering
Room 143
University College Dublin
Dublin 4, Ireland

VI. CONCLUDING REMARKS

Beginners studying chaos are often discouraged by the immense literature that has accumulated over the years on this subject. Many are frustrated if not intimidated by the unproductive chores of deciphering the numerous jargons, notations, and symbols from different disciplines, before the essence of a particular paper can be extracted. This dilemma had

been further exacerbated by the tedious task of studying many different papers, each one covering some limited aspect of bifurcation phenomena, in order to obtain a broad understanding of chaos. This two-part paper has demonstrated, via numerous experimental results, that since Chua's oscillator can exhibit virtually all the reported bifurcation and chaotic phenomena observed from physical systems from different disciplines, it suffices to study a simple system in-depth. In particular, the special case $R_0 = 0$ (Chua's circuit) is adequate for beginners [18]. However, it must be unfolded (by adding a linear resistor R_0 in this case) in order to exploit its full potentials. At the very least, this unfolding has provided a *unification* of many previous publications [5]–[15], e.g., of seemingly unrelated systems from different disciplines. This unification is significant because it is no longer necessary to study the members of \tilde{C} as distinct systems since one theory now covers them all. In particular, no new bifurcation phenomena or surprises can be expected by studying the other systems in \tilde{C} . This paper therefore will help future researchers from carrying out unproductive investigations of future new systems which are qualitative similar to the dynamics of Chua's oscillator.

APPENDIX

For the convenience of the reader, we show in this Appendix, in tabular format (see Tables AI and AII), the parameters of several systems in \tilde{C} and the parameters of corresponding

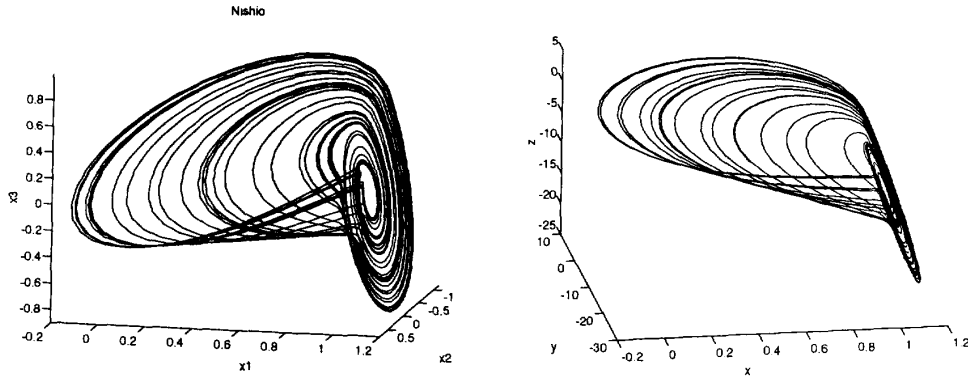

Fig. A7.

Chua's oscillators that generate qualitatively similar behaviors. We also give the linear equivalency $\tilde{\mathbf{T}}$ that transforms orbits of the Chua's oscillator to orbits of the corresponding system in \mathcal{C} . The mapping will not be exact for cases where a small perturbation is added to the eigenvalues parameters to generate the corresponding Chua's oscillator. The Lyapunov exponents of the system in \mathcal{C} , and the corresponding Chua's oscillator should match except for a positive scaling constant, except for the cases where a small perturbation is added to the eigenvalues parameters, in which case, the Lyapunov exponents of the two systems are slightly mismatched. The same remark holds for the eigenvalues in each linear region.

Finally, we show 3-D plots of the attractor of these systems in \mathcal{C} and the attractor in the corresponding Chua's oscillator (see Figs. A1–A7). The attractor of a system in \mathcal{C} is shown on the left, and the corresponding attractor in Chua's oscillator is shown on the right.

Each member of \mathcal{C} can be written as

$$\frac{d\mathbf{x}}{dt} = \mathbf{A}\mathbf{x} + \mathbf{b}, \quad x_1 \geq 1 \quad (\text{A1})$$

$$= \mathbf{A}\mathbf{x} - \mathbf{b}, \quad x_1 \leq -1 \quad (\text{A2})$$

$$= \mathbf{A}_0\mathbf{x}, \quad -1 \leq x_1 \leq 1 \quad (\text{A3})$$

where

$$\mathbf{A} = \begin{bmatrix} a_{11} & a_{12} & a_{13} \\ a_{21} & a_{22} & a_{23} \\ a_{31} & a_{32} & a_{33} \end{bmatrix}, \quad \mathbf{b} = \begin{bmatrix} b_1 \\ b_2 \\ b_3 \end{bmatrix}. \quad (\text{A4})$$

For each system in \mathcal{C} , we use Algorithm 1 to construct the corresponding Chua's oscillator with circuit parameters

$C_1, C_2, G, R_0, L, G_a, G_b, E$ (after perturbing the eigenvalue parameters if necessary) whose state equations are given by

$$\begin{aligned} \frac{dv_1}{dt} &= \frac{1}{C_1} [G(v_2 - v_1) - f(v_1)] \\ \frac{dv_2}{dt} &= \frac{1}{C_2} [G(v_1 - v_2) + i_3] \\ \frac{di_3}{dt} &= -\frac{1}{L} (v_2 + R_0 i_3). \end{aligned} \quad (\text{A5})$$

These two systems are related by a linear conjugacy as follows [3]:

$$\mathbf{x} = \mathbf{T} \begin{pmatrix} v_1 \\ v_2 \\ i_3 \end{pmatrix} \quad (\text{A6})$$

where $\mathbf{T} = \mathbf{K}^{-1}\tilde{\mathbf{K}}$ and (A7), which is shown at the bottom of this page, and

$$\tilde{\mathbf{K}} = \begin{pmatrix} 1 & 0 & 0 \\ -\left(\frac{G+G_b}{C_1}\right) & \frac{G}{C_1} & 0 \\ \left(\frac{G+G_b}{C_1}\right)^2 + \frac{G^2}{C_1 C_2} & -\frac{G(G+G_b)}{C_1^2} - \frac{G^2}{C_1 C_2} & \frac{G}{C_1 C_2} \end{pmatrix}. \quad (\text{A8})$$

In terms of the dimensionless form

$$\left. \begin{aligned} \frac{d\tilde{x}}{d\tilde{\tau}} &= k\alpha(\tilde{y} - \tilde{x} - f(\tilde{x})) \\ \frac{d\tilde{y}}{d\tilde{\tau}} &= k(\tilde{x} - \tilde{y} + \tilde{z}) \\ \frac{d\tilde{z}}{d\tilde{\tau}} &= k(-\beta\tilde{y} - \gamma\tilde{z}) \\ f(\tilde{x}) &= b\tilde{x} + \frac{1}{2}(a-b)\{|\tilde{x}+1| - |\tilde{x}-1|\} \end{aligned} \right\} \quad (\text{A9})$$

$$\mathbf{K} = \begin{pmatrix} 1 & 0 & 0 \\ a_{11} & a_{12} & a_{13} \\ a_{11}a_{11} + a_{12}a_{21} + a_{13}a_{31} & a_{11}a_{12} + a_{12}a_{22} + a_{13}a_{32} & a_{11}a_{13} + a_{12}a_{23} + a_{13}a_{33} \end{pmatrix} \quad (\text{A7})$$

$$\mathbf{K} = \begin{pmatrix} 1 & 0 & 0 \\ a_{11} & a_{12} & a_{13} \\ a_{11}a_{11} + a_{12}a_{21} + a_{13}a_{31} & a_{11}a_{12} + a_{12}a_{22} + a_{13}a_{32} & a_{11}a_{13} + a_{12}a_{23} + a_{13}a_{33} \end{pmatrix} \quad (\text{A11})$$

we have a topological equivalency given by

$$\mathbf{x} = \tilde{\mathbf{T}} \begin{pmatrix} \tilde{x} \\ \tilde{y} \\ \tilde{z} \end{pmatrix} \quad (\text{A10})$$

where $\tilde{\mathbf{T}} = \mathbf{K}^{-1}\tilde{\mathbf{K}}$, \mathbf{K} is the same as before (see (A11) on the previous page), and

$$\tilde{\mathbf{K}} = \begin{pmatrix} 1 & 0 & 0 \\ -k\alpha(1+b) & k\alpha & 0 \\ (\alpha(1+b))^2 + \alpha & -\alpha^2(1+b) - \alpha & \alpha \end{pmatrix} \quad (\text{A12})$$

ACKNOWLEDGMENT

The authors would like to thank L. Pivka for his help in the preparation of this manuscript.

REFERENCES

- [1] L. O. Chua, C. W. Wu, A. Huang, and G. Q. Zhong, "A universal circuit for studying and generating chaos, part I: Routes to chaos," *IEEE Trans. Circuits Syst. —I: Fundamental Theory Applications*, this issue.
- [2] R. N. Madan, "Observing and learning chaotic phenomena from Chua's circuit," in *Proc. 35th Midwest Symp. Circuits Syst.*, 1992, pp. 736–745.
- [3] L. O. Chua, "Global unfolding of Chua's circuits," *IEICE Trans. Fundamentals Electron. Commun. Comput. Sci.*, vol. E76-A, pp. 704–734, 1993.
- [4] P. Dergeel, "Chua's oscillator: A zoo of attractors," *J. Circuits, Syst. Comput.*, vol. 3, June 1993.
- [5] R. W. Brockett, "On conditions leading to chaos in feedback systems," in *Proc. IEEE Conf. Decision Contr.*, 1982, pp. 932–936.
- [6] M. J. Ogorzalek, "Order and chaos in a third order RC ladder network with nonlinear feedback," *IEEE Trans. Circuits Syst.*, vol. 36, pp. 1221–1230, 1989.
- [7] C. T. Sparrow, "Chaos in three-dimensional single loop feedback system with a piecewise linear feedback function," *J. Math. Anal. Applications*, vol. 83, pp. 275–291, 1981.
- [8] P. Couillet, C. Tresser, and A. Arnéodo, "Transition to stochasticity for a class of forced oscillators," *Phys. Lett.*, vol. 72A, nos. 4,5, pp. 268–270, 1979.
- [9] A. Arnéodo, P. Couillet, and C. Tresser, "Possible new strange attractors with spiral structure," *Commun. Math. Phys.*, vol. 79, pp. 573–579, 1981.
- [10] A. Arnéodo, P. Couillet, and E. A. Spiegel, "Chaos in a finite macroscopic system," *Phys. Lett.*, vol. 92A, no. 8, pp. 369–373, 1982.
- [11] M. Shinriki, M. Yamamoto, and S. Mori, "Multimode oscillations in a modified van der Pol oscillator containing a positive nonlinear conductance," *Proc. IEEE*, vol. 69, pp. 394–395, Mar. 1981.
- [12] E. Freire, L. G. Franquelo, and J. Aracil, "Periodicity and chaos in an autonomous electronic system," *IEEE Trans. Circuits Syst.*, vol. 31, pp. 237–247, Mar. 1984.
- [13] A. S. Dmitriev and V. Y. Koslov, "Stochastic oscillations in a self-excited oscillator with a first-order inertial delay," *Radiotekhnika i elektronika*, vol. 29, p. 2389, 1984 (in Russian).
- [14] A. Volkovskii and N. F. Rul'kov, "Use of one-dimensional mapping for an experimental study of the stochastic dynamics of an oscillator," *Sov. Tech. Phys. Lett.*, vol. 14, pp. 656–658, Aug. 1988.
- [15] N. F. Rul'kov, A. R. Volkovskii, A. Rodriguez-Lozano, E. D. Ríó, and M. G. Velarde, "Mutual synchronization of chaotic self-oscillators with dissipative coupling," *Int. J. Bifurcation Chaos*, vol. 2, no. 3, pp. 669–676, 1992.
- [16] T. Parker and L. O. Chua, *Practical Numerical Algorithms for Chaotic Systems*. New York: Springer-Verlag, 1989.
- [17] Y. Nishio, N. Inaba, and S. Mori, "Chaotic phenomena in an autonomous circuit with nonlinear inductor," in *Proc. ISCAS*, 1990.

Leon O. Chua, for photograph and biography please see page 639 of this issue.

Chai Wah Wu, photograph and biography not available at time of publication.

Anshan Huang, photograph and biography not available at time of publication.

Guo-Qun Zhong, photograph and biography not available at time of publication.